

M-D Pneumatics™

COMPETITOR⁺™

Rotary Positive Displacement Air Blower

Models	2002	3002	4002	5003	6005	7006
	2004	3003	4005	5006	6008	7011
		3006	4007	5009	6015	7018

INSTALLATION OPERATION MAINTENANCE REPAIR MANUAL

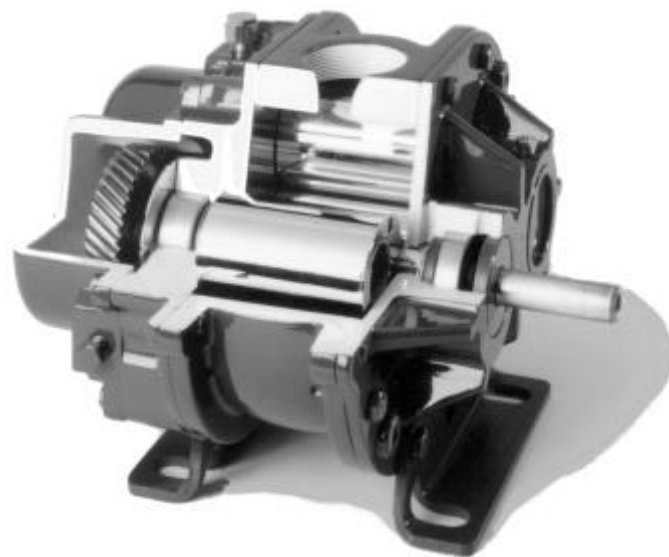

WARNING

DO NOT OPERATE BEFORE
READING MANUAL.



05/2003

LEADING THE SEARCH FOR INNOVATIVE SOLUTIONS



TUTHILL
Vacuum and Blower Systems

4840 West Kearney Street
Springfield, Missouri USA 65803-8702
Tel 417 865-8715 800 825-6937 Fax 417 865-2950
E-mail: mdpneumatics@tuthill.com

<http://pneumatics.tuthill.com>

SAFETY INSTRUCTIONS

1. Do not operate before reading the enclosed instruction manual.
2. Use adequate protection, warning and safety equipment necessary to protect against hazards involved in installation and operation of this equipment.

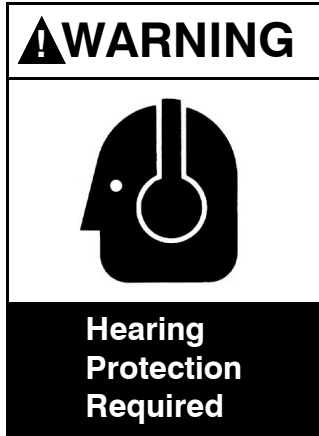

SAFETY WARNING

- Keep hands and clothing away from rotating machinery, inlet and discharge openings.
- Blower and drive mounting bolts must be secured.
- Drive belts and coupling guards must be in place.
- Noise level may require ear protection.
- Blower heat can cause burns if touched.

TUTHILL VACUUM AND BLOWER SYSTEMS

Springfield, MO USA

NOTICE

The above safety instruction tags were attached to your unit prior to shipment. Do not remove, paint over or obscure in any manner.

Failure to heed these warnings could result in serious bodily injury to the personnel operating and maintaining this equipment.

TABLE OF CONTENTS

SECTION	PAGE
INTRODUCTION	4
OPERATING DATA	4
INSTALLATION	5
LUBRICATION	6
PREVENTATIVE MAINTENANCE	7
STARTUP CHECKLIST	7
TROUBLESHOOTING	8
RECOMMENDED SHUTDOWN PROCEDURE	9
DISASSEMBLY AND INSPECTION	10
BLOWER DISASSEMBLY	10
BLOWER ASSEMBLY	12
MAINTENANCE AND SERVICE SPECIFICATIONS SHEET	14
RECOMMENDED LUBRICANTS AND OIL RESERVOIR CAPACITIES	15
SPECIAL TOOL DRAWINGS	16
CUTAWAY VIEW AND PARTS LIST	17
WARRANTY STATEMENT	18

SAFETY PRECAUTIONS

For equipment covered specifically or indirectly in this instruction book, it is important that all personnel observe safety precautions to minimize the chances of injury. Among many considerations, the following should particularly be noted:

- Blower casing and associated piping or accessories may become hot enough to cause major skin burns on contact.
- Internal and external rotating parts of the blower and driving equipment can produce serious physical injuries. Do not reach into any opening in the blower while it is operating, or while subject to accidental starting. Cover external moving parts with adequate guards.
- Disconnect power before doing any work, and avoid bypassing or rendering inoperative any safety or protective devices.
- If blower is operated with piping disconnected, place a strong, coarse screen over the inlet and avoid standing in discharge air stream.
- Avoid extended exposure in close proximity to machinery with high intensity noise levels.
- Use proper care and good procedures in handling, lifting, installing, operating, and maintaining the equipment.
- Other potential hazards to safety may also be associated with operation of this equipment. All personnel working in or passing through the area should be warned by signs and trained to exercise adequate general safety precautions.
- Hearing protection may be required depending on silencing capabilities.

CAUTION!

Most COMPETITOR PLUS™ blowers are shipped from the factory in a left hand drive, vertical flow configuration.

If drive shaft location is changed, the oil level plug and breather must be relocated to proper positions, as shown to the right.

Failure to change plug location will result in blower failure and void the product warranty.

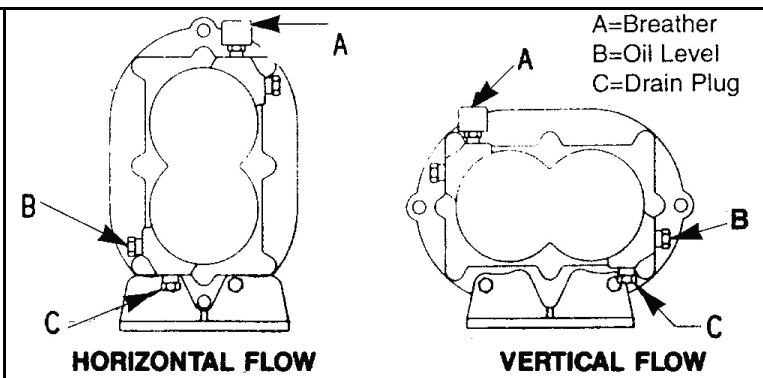

INTRODUCTION

CONGRATULATIONS on your purchase of a new M-D Pneumatics™ COMPETITOR® PLUS™ Rotary Positive Displacement Air Blower from Tuthill Vacuum and Blower Systems. Please examine the blower for shipping damage, and if any damage is found, report it immediately to the carrier. If the blower is to be installed at a later date make sure it is stored in a clean, dry location and rotated regularly. Make sure covers are kept on all openings. If blower is stored outdoors be sure to protect it from weather and corrosion.

COMPETITOR PLUS blowers are built to exacting standards and if properly installed and maintained will provide many years of reliable service. We urge you to take time to read and follow every step of these instructions when installing and maintaining your blower. We have tried to make these instructions as straightforward as possible. We realize getting any new piece of equipment up and running in as little time as possible is imperative to production.

WARNING: Serious injury can result from operating or repairing this machine without first reading the service manual and taking adequate safety precautions.

IMPORTANT: Record the blower model and serial numbers of your machine in the OPERATING DATA form below. You will save time and expense by including this reference identification on any replacement part orders, or if you require service or application assistance.

OPERATING DATA

It will be to the user's advantage to have the requested data filled in and available in the event a problem should develop in the blower or the system. This information is also helpful when ordering spare parts.

Model No. _____	V-Belt Size _____ Length _____
Serial No. _____ (Recorded from nameplate on unit)	Type of Lubrication: _____
Startup Date _____	_____
Blower RPM _____	Pressure _____
Blower Sheave Diameter _____	Vacuum _____
Motor Sheave Diameter _____	Any other special accessories with this unit
Motor RPM _____ HP _____	_____

NOTES: _____

INSTALLATION

WARNING: Customers are cautioned to provide adequate protection, warning and safety equipment necessary to protect personnel against hazards involved in the installation and operation of this equipment in the system or facility.

Do not use air blowers on explosive or hazardous gases. Each size blower has limits on pressure differential, running speed, and discharge temperature, which **must not** be exceeded. These limits are shown on the table "Maximum Operating Limits" on page 14.

LOCATION

Install the blower in a clean, dry, and well lighted area if possible. Leave plenty of room around the blower for inspection and maintenance.

FOUNDATION

We recommend a solid foundation be provided for permanent installation. It is necessary that a suitable base be used, such as a steel combination base under blower and motor, or a separate sole plate under each.

Before tightening the bolts, check to see that both mounting feet are resting evenly on the foundation, shim as necessary to eliminate stress on the base when the bolts are tightened.

Where a solid foundation is not feasible, care must be taken to insure that equipment is firmly anchored to adequate structural members.

DRIVE

When the blower is V-belt driven the sheaves must be positioned so that the hub face of the blower sheave is not more than 1/4" (6.5 mm) from the blower drive end plate and the driver sheave is as close to the driver bearing as possible. Care should be taken when installing sheave onto shaft. The faces of the sheaves should be accurately in line to minimize belt wear.

Adjust the belt tension to the belt manufacturer's specifications.

For installations where the blower is to be operated by direct drive, selection of the driver should be such as not to exceed the maximum speed ratings of the blower. (See table "Maximum Operating Limits" on page 14.)

For direct drive applications, a flexible type coupling should be used to connect driver and blower shafts. The two shafts must be aligned within .005" (.13 mm) T.I.R. (Total Indicated Runout). Face alignment must be within .002" (.05 mm).

PROTECTIVE MATERIALS

Remove protective materials from the shaft.

Remove the protective covers from the inlet and outlet ports and inspect the interior for dirt and foreign material.

WARNING: Keep hands, feet, foreign objects and loose clothes from inlet and outlet openings to avoid injury or damage if lobes are to be rotated at this point.

LUBRICATION

Do not start up the blower until you are positive that it has been properly and fully lubricated. (See Lubrication Section on page 6.)

PIPING

Inlet and outlet connections on all blowers are large enough to handle maximum volume with minimum friction loss. Maintain same diameter piping. Silencers must not be supported by the blower. Stress loads and bending moments must be avoided.

Be certain all piping is clean internally before connecting to the blower. We recommend placing a 16-mesh wire screen backed with hardware cloth at or near the inlet connections for the first 50 hours of use until the system is clean. Make provisions to clean the screen after a few hours of operation and completely discard it once the system is clean, as it will eventually deteriorate and small pieces going into the blower can cause serious damage. A horizontal or vertical air flow piping configuration is easily achieved by rearranging the mounting feet position.

WARNING: Do not operate equipment without adequate silencing devices since high noise level may cause hearing damage. (Reference OSHA Standards.)

RELIEF VALVES

We recommend the use of relief valves to protect against excessive pressure or vacuum conditions. These valves should be tested at initial start-up to be sure they are properly adjusted to relieve at or below the maximum pressure differential rating of the blower.

CAUTION: Upon completion of the installation, and before applying power, rotate the drive shaft by hand. It must move freely. If it does not, look for uneven mounting, piping strain, excessive belt tension or coupling misalignment or any other cause for binding. If blower is removed and still does not rotate freely, check inside the blower housing for foreign material.

LUBRICATION

The bearings at the drive shaft end of the blower are grease lubricated. The timing gears and bearings at the other end are lubricated by the lower timing gear (when in the horizontal flow configuration) acting as a oil slinger, carrying oil to the upper timing gear and providing splash lubrication for the bearings. Both timing gears act as slingers when the blower is in the vertical flow configuration.

Use a good grade industrial type anti-rust, oxidation and foam inhibited oil. Recommended lubricants are shown on page 15.

FILLING PROCEDURE

To fill the gear housing, remove the oil breather* (A) and oil level plug (B) on the gear end. Fill the gear housing until oil drips out of the oil level hole. Replace plugs in their respective holes.

*Models 2002 and 2004 do not have oil breathers. In this case, remove plug to fill.

WARNING: Do not start the blower until you are sure oil has been put in the gear housing.

GREASE LUBRICATED BEARINGS

Service drive end bearings at regular intervals. (See "Suggested Lubrication Intervals for Grease Lubricated Bearings" below.) Use NLGI #2 premium grade, petroleum base grease with high temperature resistance and good mechanical stability, such as PneuLube grease available from your local Tuthill Pneumatics Sales Professional. Using a pressure gun, force new grease into each bearing until traces of clean grease come out of the relief fitting.

CAUTION: To avoid blowing out the drive shaft seal, do not inject grease too rapidly.

LUBRICATION INSTRUCTIONS FOR OIL LUBRICATED GEARS AND BEARINGS

Add fresh oil as required to maintain proper level. Drain and refill after the first 100 hours of operation and thereafter every 1,000 hours of operation under normal service, more frequently depending on the type of oil and oil operating temperature. Use a good quality oil, such as PneuLube, available through your local Tuthill Pneumatics Sales Professional.

See page 15 for list of recommended lubricants.

SUGGESTED LUBRICATION INTERVALS FOR GREASE LUBRICATED BEARINGS

SPEED IN RPM	OPERATING HOURS PER DAY		
	8	16	24
GREASING INTERVALS IN WEEKS			
750-1000	7	4	2
1000-1500	5	2	1
1500-2000	4	2	1
2000-2500	3	1	1
2500-3000	2	1	1
3000 and up	1	1	1

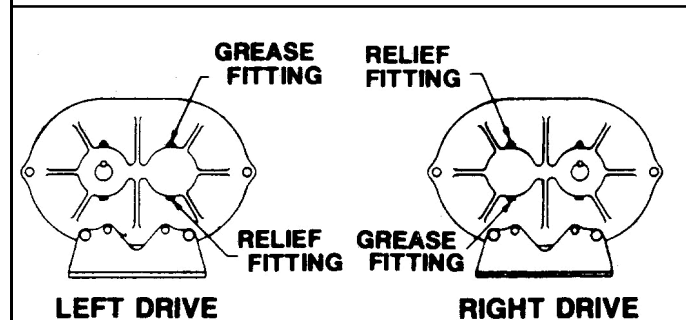
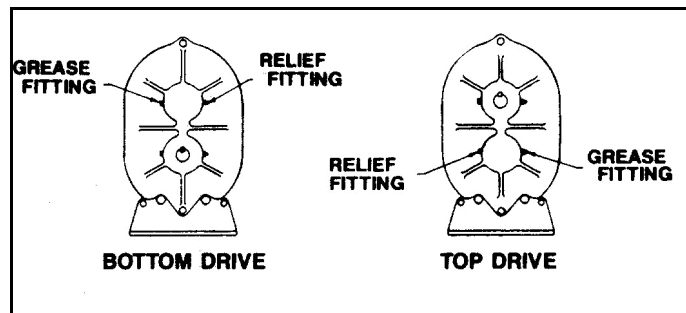
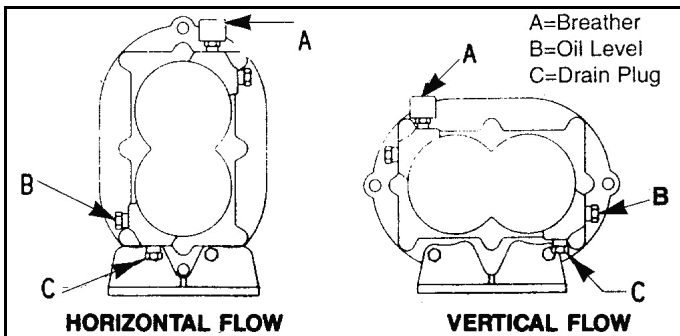

PREVENTATIVE MAINTENANCE

A good maintenance program will add years of service to your blower.

A newly installed blower should be checked frequently during the first month of operation, especially lubrication. Check oil level in both the drive end and gear end of the blower and add oil as needed. Complete oil changes are recommended every 1000 operating hours, or more frequently depending on the type of oil and oil operating temperature.

The following is recommended as a minimum maintenance program.

DAILY MAINTENANCE	WEEKLY MAINTENANCE	MONTHLY MAINTENANCE
<ol style="list-style-type: none"> 1. Check and maintain oil level, and add oil as necessary. 2. Check for unusual noise or vibration (See Troubleshooting on page 8) 	<ol style="list-style-type: none"> 1. Clean all air filters. A clogged air filter can seriously affect the efficiency of the blower and cause overheating and oil usage. 2. Check relief valve to assure it is operating properly 	<ol style="list-style-type: none"> 1. Inspect the entire system for leaks. 2. Inspect condition of oil and change if necessary (see page 6) 3 Check drive belt tension and tighten if necessary.

START-UP CHECKLIST

We recommend that these startup procedures be followed in sequence and checked (P) off in the boxes provided in any of the following cases:

- During initial installation
- After any shutdown period
- After maintenance work has been performed
- After blower has been moved to a new location

--	--	--	--

Date Checked

--	--	--	--

1. Check the unit for proper lubrication. Proper oil level cannot be over-emphasized. Refer to Lubrication Section.

--	--	--	--

2. Check Alignment.

For Direct Drive: Check coupling and shaft alignment.
For Belt Drive: Check for proper belt alignment and tension.

--	--	--	--

3. Turn the rotors by hand to be certain they do not bind.

WARNING: Disconnect power. Make certain power is off and locked out before touching any rotating element of the blower, motor or drive components.

--	--	--	--

4. "Bump" the unit with the motor a few times to check rotation and to be certain it turns freely and smoothly.

--	--	--	--

5. Start the unit and operate it for 30 minutes at no load. During this time, feel the cylinder for hot spots. If minor hot spots occur, refer to the Troubleshooting Section (page 8).

--	--	--	--

6. Apply the load and observe the operation of the unit for one hour. Check the unit frequently during the first day of operation.

--	--	--	--

7. If minor malfunctions occur, discontinue operation and refer to the Troubleshooting Section (page 8).

TROUBLESHOOTING

Although **COMPETITOR® PLUS™** blowers are well designed and manufactured, problems may occur due to normal wear and the need for readjustment. The chart below lists symptoms that may occur along with probable causes and remedies.

SYMPTOM	PROBABLE CAUSE	REMEDIES
Loss of oil.	Gear housing not tightened properly. Lip seal failure. Insufficient sealant. Loose drain plug.	Tighten gear housing bolts. Disassemble and replace lip seal. Remove gear housing and replace sealant. (See Disassembly and Inspection section on page 10) Tighten drain plug.
Excessive bearing or gear wear.	Improper lubrication. Excessive belt tension. Coupling misalignment.	Correct oil level. Replace dirty oil. (See Lubrication section on page 6) Check belt manufacturer's specifications for tension and adjust accordingly. Check carefully, realign if necessary.
Lack of volume.	Slipping belts. Worn lobe clearances. Speed too low. Obstruction in piping.	Check belt manufacturer's specifications for tension and adjust accordingly. Check for proper clearances (See Assembly Clearances on page 14) Increase blower speed within limits. Check system to assure an open flow path.
Knocking.	Unit out of time. Distortion due to improper mounting or pipe strains. Excessive pressure differential. Worn gears.	Re-time. Check mounting alignment and relieve pipe strains. Reduce to manufacturer's recommended pressure. Examine relief valve and reset if necessary. Replace timing gears (See Disassembly and Inspection section on page 10)
Excessive blower temperature.	Too much or too little oil in gear reservoir. Too low operating speed. Clogged filter or silencer. Excessive pressure differential. Elevated inlet temperature. Worn lobe clearances.	Check oil level. (See Lubrication section on page 6) Increase blower speed within limits. Remove cause of obstruction. Reduce pressure differential across the blower. Reduce inlet temperature. Check for proper clearances (See Assembly Clearances on page 14)
Rotor end or tip drag.	Insufficient assembled clearances. Case or frame distortion. Excessive operating pressure. Excessive operating temperature.	Correct clearances (See Assembly Clearances on page 14) Check mounting and pipe strain. Reduce pressure differential. Reduce pressure differential or reduce inlet temperature.
Vibration.	Belt or coupling misalignment. Lobes rubbing. Worn bearings or gears. Unbalanced or rubbing lobes. Driver or blower loose. Piping resonance.	Check carefully, realign if necessary. Check cylinder for hot spots, then check for lobe contact at these points. Correct clearances (See Assembly Clearances on page 14) Check condition of gears and bearings; replace if necessary. Possible buildup on casing or lobes, or inside lobes. Remove buildup and restore clearances. Check mounting and tighten if necessary. Check pipe supports, check resonance of nearby equipment, check foundation.

RECOMMENDED SHUTDOWN PROCEDURE TO MINIMIZE RISK OF FREEZING OR CORROSION

When high humidity or moisture is present in an air piping system, condensation of water can occur after the blower is shut down and the blower begins to cool. This creates an environment favorable to corrosion of the iron internal surfaces, or in cold weather, the formation of ice. Either of these conditions can close the operating clearances, causing the blower to fail upon future start-up.

The following shutdown procedure outlined below minimizes the risk of moisture condensation, corrosion and freezing. **Care must be taken so as not to overload or overheat the blower during this procedure.**

1. Isolate the blower from the moist system piping, allowing the blower to intake atmospheric air. Operate the blower under a slight load allowing the blower to heat within safe limits. The heat generated by the blower will quickly evaporate residual moisture.
2. For carpet cleaning applications, after the work is completed, simply allow the blower to run a few (3-5) minutes with the suction hose and wand attached. The suction hose and wand will provide enough load to the blower to evaporate the moisture quickly.
3. For extended shutdown, inject a small amount of a light lubricating oil such as 3-in-One® or a spray lubricant such as WD-40® into the inlet of the blower just prior to shutdown. The lubricant will provide an excellent protective coating on the internal surfaces. If using a spray lubricant, exercise care to prevent the applicator tube from getting sucked into the blower. The applicator tube will damage the blower, most likely to the point that repair would be required.

January, 2001

3-in-One and WD-40 are registered trademarks of WD-40 Company.

DISASSEMBLY & INSPECTION

With proper maintenance and lubrication, normal life expectancy for gears, bearings, and seals can be achieved. However, over a period of time these parts must be repaired or replaced to maintain the efficiency of your blower. This section is written in a way that will allow you to completely disassemble your blower. The inspection of certain repairable or replaceable parts is referred to at the point of disassembly where these parts are exposed. If at any point of inspection, repair or replacement is deemed necessary, appropriate instruction will be given to achieve these repairs or replacements.

Remove the oil drain plug [18] in the bottom of the gear cover [5] and drain the oil. Take out eight cap screws [16] and remove the gear cover. It may be necessary to tap the sides with a mallet or wooden block to break the seal joint.

Gears are now exposed for visual inspection. Items in brackets [] are referenced to item numbers on page 17.

Inspect the gears for the following:

- Broken Teeth
- Chipped Teeth
- Uneven Wear
- Excessive Wear
- Any Other Abnormalities

WARNING: Before performing any repair or replacement, disconnect and lock out power.

BLOWER DISASSEMBLY

Position blower with the drive gear on the left when facing the gears. Remove socket head screws and washers. [items 29 & 26].

Align timing marks and count four (4) teeth down and place reference marks on the gears. (Refer to Figure 1 below)

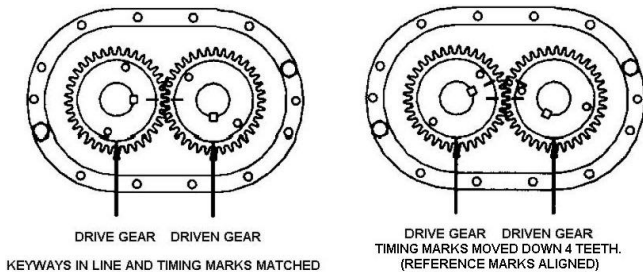

Figure 1. Timing Gear Alignment

Align reference marks and use puller to pull the driven gear. (Gear on right side). (Refer to Figure 2 below)



Figure 2. Pulling Driven Gear with Jaw Puller

Use puller to remove drive gear. A bar puller (Refer to Figure 3 below) or jack screws can be used.

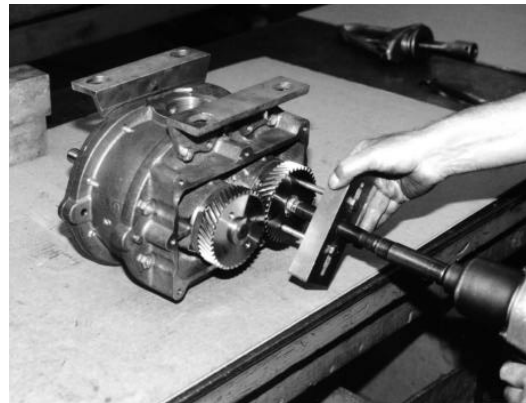

Figure 3. Pulling Driven Gear with Bar Puller

Remove shim and spacer. [Items 28 & 30]

Turn blower around and remove grease cover [Item 10]

Remove eight (8) cap screws. [Item 15]

Use jackscrews to remove end plate. (Refer to Figure 4 below)

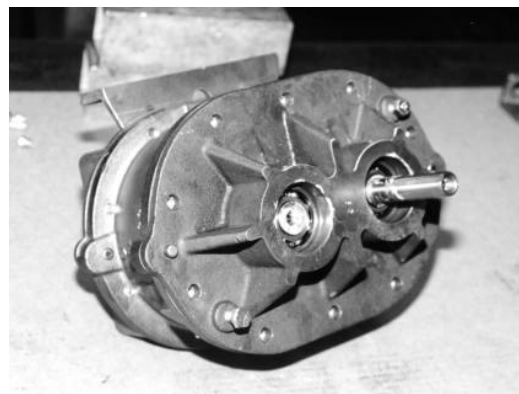

Figure 4. Pulling Drive End Plate

Press rotors out of end plate in press if available. If press is not available, support end plate and rotors in the housing. Block up housing and use a soft mallet to drive the rotors out. (Refer to Figure 5 below)

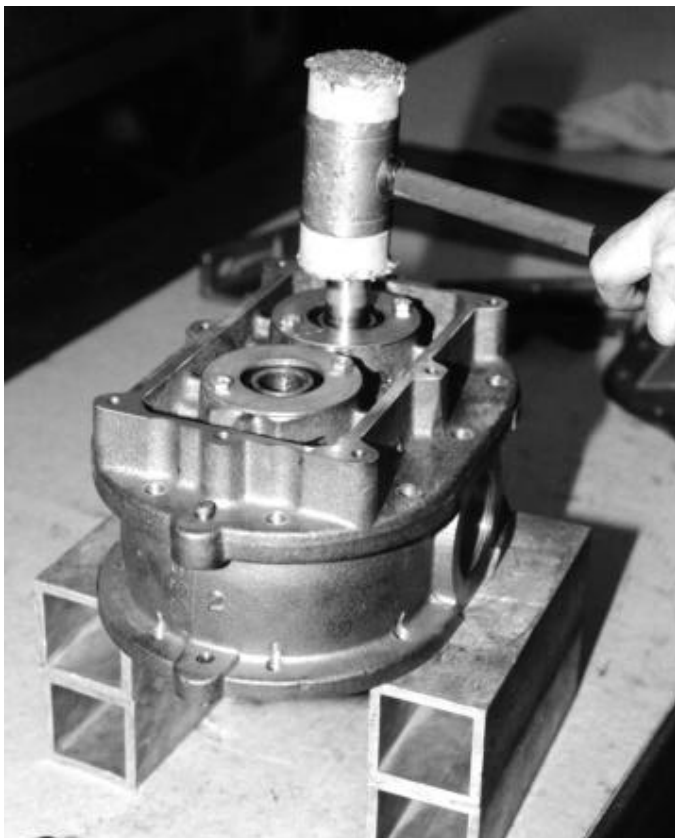

Figure 5. Driving Rotors Out Using Soft Mallet

A jaw type puller can also be used. (Refer to Figure 6 below)

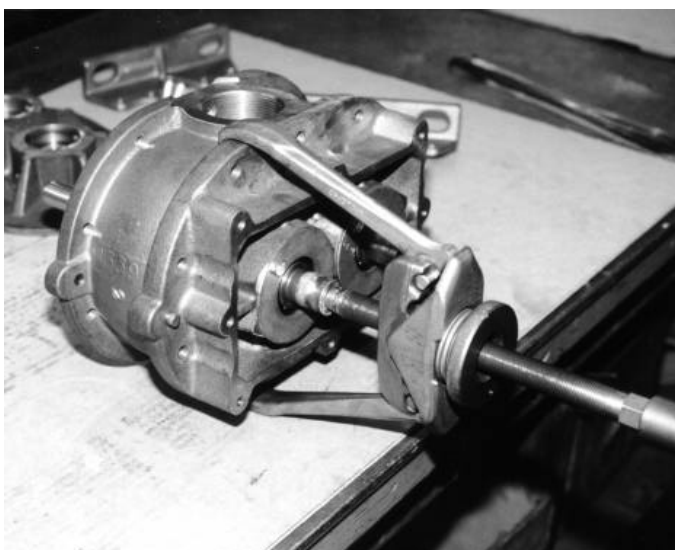

Figure 6. Driving Rotors Out Using Jaw Puller

Using a tube or round bar of a slightly smaller diameter than the shaft clearance holes in the end plates, tap the bearings out of the end plates. Bearing retainers [Item 22] must be removed before knocking out the bearings. (Refer to Figure 7 below)



Figure 7. Tapping Bearings Out of End Plates

Remove seals from both end plates with a punch or dull chisel. The seals **will** be damaged during removal and must be replaced.

Inspect all parts for wear and or damage.

Clean and inspect all parts for burrs and polish seal journals with at least 320 grit emery or crocus cloth.

Items in brackets [] are referenced to item numbers on page 17.

BLOWER ASSEMBLY

After thorough cleaning of the seal and bearing bores of both end plates apply a thin coat of sealant on the outside diameter of the new seals and press them into the end plate using a tool that will bear on the outer edge of the seal. Spring side of the seal should be facing you. Apply a thin coat of grease to the seal lip.

Using the drive end plate as a fixture, support it high enough so the input shaft of the drive rotor clears the assembly surface. (Refer to Figure A1 below). Place rotors in fixture with the drive rotor to the left. (See Figures A1 and A2 below)

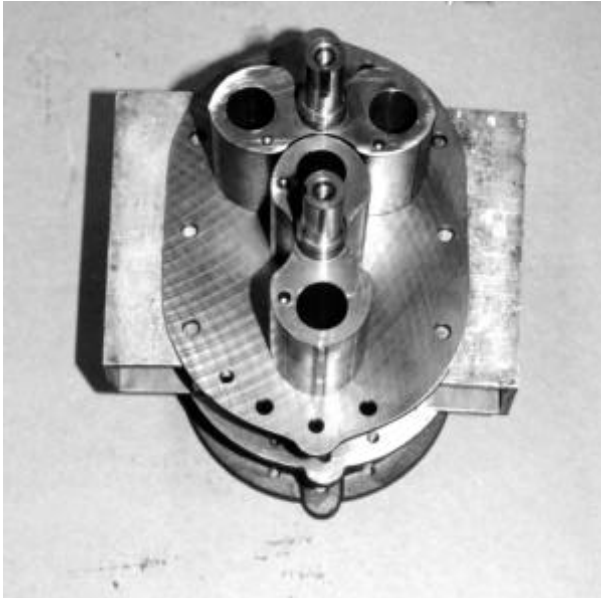

Figure A1. Rotors Assembled on Drive End Plate

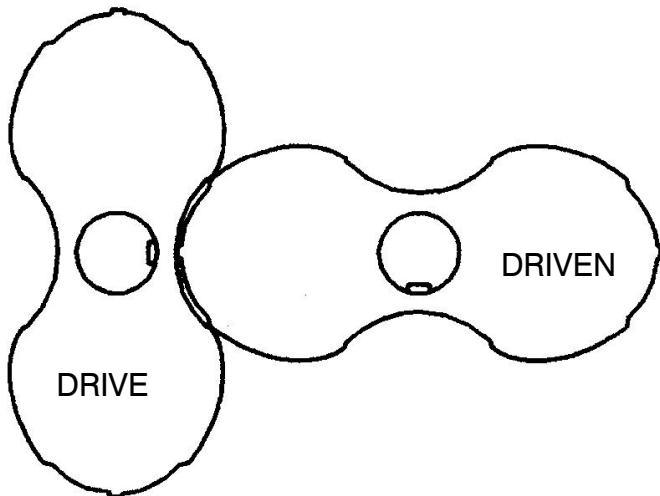

Figure A2. Detail of Proper Keyway Positions
(NOTE: Keyway positions are exactly opposite for models 6005, 6008 and 6015)

Place end plate [Item 4] on rotors.

Apply a thin coat of lubricant on the rotor shafts and the inner race of the bearings. Tap the bearings [13] into place using a tube with a flanged end that will contact both the inner and outer bearing races. (Refer to Figure A3 below).



Figure A3. Tapping Bearings into End Plates

Rotor alignment will be opposite that of Figure A2 on all 6" units (keyway on drive rotor will be up and driven to the right).

WARNING: Keep hands and loose clothing away from lobes and gears.

Install bearing retainers [Items 22 & 25] to both bearings.

Check clearances between the end of the rotors and the face of the end plate. Refer to assembly clearances chart on page 14 for proper clearances for your model blower, and refer to page 13 for procedures for checking and adjusting clearances.

If clearances check OK, put a spacer [28] and a shim [30] on each shaft. Timing shims that were removed should be put back on the shaft from which they were removed.

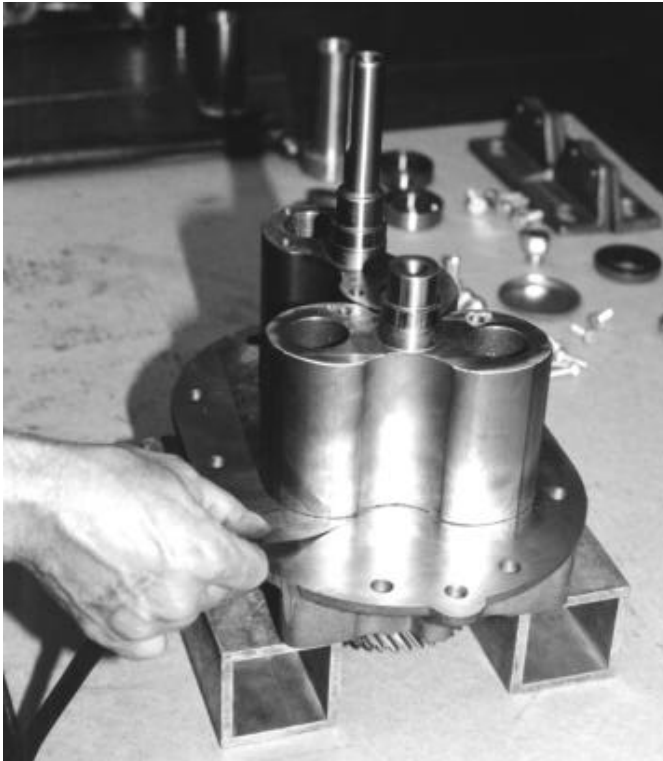

Figure A4. Checking Gear End Clearances

Lubricate shafts and bores on gears. Begin by pressing on the DRIVE gear. This will be pressed on the drive rotor, which is to the left.

Start the driven gear on the shaft and align the reference timing marks and press gear on. Lock gears in place with cap screw [29] and washer [26]. Turn assembly over and rest the unit on the cap screws and washers on the gear end.

Set dowel pins [9] in housing and position housing over the rotors and fasten with cap screws [15]. Check housing to rotor clearance. A depth mic can be used.

Set on drive end plate [3] and fasten with cap screws [15]. (**ATTENTION:** There are four cap screws [17] which are used to fasten the feet on.) Lubricate shafts and bearings. Install the ball bearing [12] on the driven rotor and the roller bearing [11] on the input shaft.

Install grease cover [Item 10] and drive shaft seal [23].

Install any removed plugs [18] and replace breather [27] if required.

Items in brackets [] are referenced to item numbers on page 17.

ADJUSTING ROTOR INTERLOBE CLEARANCE

Using feeler gauges take interlobe readings and record on each side of housing as indicated in Figure A5 below. By removing or adding shim behind the helical gear, it rotates as it is moved in or out and the driven rotor turns with it, thus changing the clearance between rotor lobes.

Changing the shim thickness .006" (.15 mm) will change the rotor lobe clearance .003" (.08 mm) or one-half the amount.

EXAMPLE: Referring to Figure A5 below, check the clearance at AA (right hand reading) and BB (left hand reading). If AA reading is .009" (.23 mm) and BB reading .003" (.08 mm) by removing .006" (.15 mm) shims, the readings will change one half the amount removed or .003" (.08 mm). AA should then read .006" (.15 mm) and BB should read .006" (.15 mm). The final reading should be within .002" (.05 mm) of each other.

To determine the amount of shim to add or remove, subtract the small figure from the larger. If the right side is higher than the left side, remove shim. If the right side is reading lower, add shim.

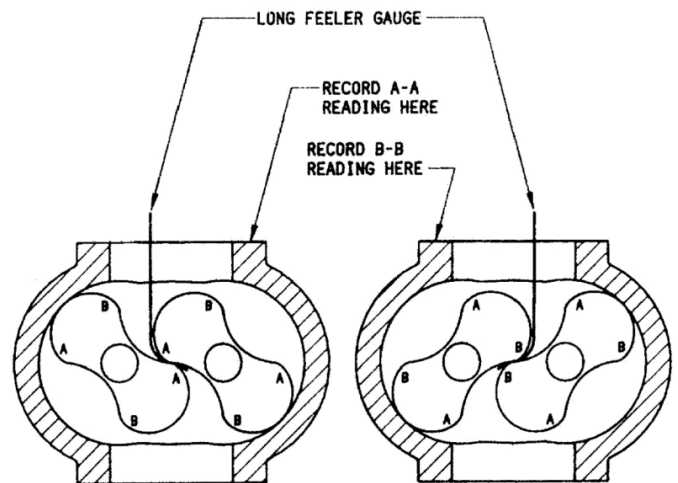

Figure A5. Checking Gear End Clearances

LUBRICATION, FINAL ASSEMBLY AND MOUNTING

Pack the bearing cavities with suitable grease. Install bearing cover plate [10]. Replace front lip seal [23] taking care not to damage the lip as it passes over the keyway. Lip must point inward toward the bearing. Apply a good quality RTV silicone sealant to the inner surface of the gear cover [5]. Install the gear cover with cap screws [16] and tighten evenly.

Fill gear cover with oil and grease front-end bearings. Refer to the Lubrication Section in this manual for oil and grease specification and filling procedures.

To insure blower has not been distorted during mounting in the installation, turn the lobes by hand to make sure they are not making contact prior to connecting to the driver.

COMPETITOR^{PLUS}™

MAINTENANCE AND SERVICE SPECIFICATIONS SHEET ASSEMBLY CLEARANCES

Metric values (mm) are shown in parentheses ()
All other values are in inches

MODEL	LOBES TO END PLATES			INTERLOBE	LOBE TO CASING	
	DRIVE END	GEAR END	TOTAL		TIP-DOWEL	TIP-PORT
2002, 2004	.004" - .007" (.10 - .18)	.003" - .005" (.08 - .13)	.008" - .011" (.20 - .28)	.005" - .009" (.13 - .23)	.002" - .004" (.05 - .10)	.003" - .006" (.08 - .15)
3002	.004" - .007" (.10 - .18)	.003" - .005" (.08 - .13)	.008" - .012" (.20 - .30)	.006" - .012" (.15 - .30)	.002" - .005" (.05 - .13)	.004" - .007" (.10 - .18)
3003	.005" - .008" (.13 - .20)	.003" - .005" (.08 - .13)	.009" - .012" (.23 - .30)	.006" - .012" (.15 - .30)	.002" - .005" (.05 - .13)	.004" - .007" (.10 - .18)
3006	.006" - .010" (.15 - .25)	.003" - .005" (.08 - .13)	.010" - .013" (.25 - .33)	.006" - .012" (.15 - .30)	.002" - .005" (.05 - .13)	.004" - .007" (.10 - .18)
4002	.004" - .009" (.10 - .23)	.004" - .006" (.10 - .15)	.009" - .013" (.23 - .33)	.008" - .012" (.20 - .30)	.003" - .006" (.08 - .15)	.005" - .008" (.13 - .20)
4005, 4007	.005" - .010" (.13 - .25)	.004" - .006" (.10 - .15)	.010" - .014" (.10 - .36)	.008" - .012" (.20 - .30)	.003" - .006" (.08 - .15)	.005" - .008" (.13 - .20)
5003	.004" - .009" (.10 - .23)	.004" - .006" (.10 - .15)	.009" - .013" (.23 - .33)	.014" - .018" (.36 - .46)	.003" - .006" (.08 - .15)	.005" - .008" (.13 - .20)
5006, 5009	.005" - .010" (.13 - .25)	.004" - .006" (.10 - .15)	.010" - .014" (.10 - .36)	.014" - .018" (.36 - .46)	.003" - .006" (.08 - .15)	.005" - .008" (.13 - .20)
6005, 6008	.008" - .013" (.20 - .33)	.005" - .007" (.13 - .18)	.015" - .019" (.38 - .48)	.010" - .014" (.10 - .36)	.004" - .007" (.10 - .18)	.006" - .009" (.15 - .23)
6015	.009" - .014" (.23 - .36)	.005" - .007" (.13 - .18)	.016" - .020" (.41 - .51)	.010" - .014" (.10 - .36)	.004" - .007" (.10 - .18)	.006" - .009" (.15 - .23)
7006	.010" - .014" (.10 - .36)	.005" - .007" (.13 - .18)	.017" - .020" (.43 - .51)	.012" - .016" (.30 - .41)	.004" - .007" (.10 - .18)	.006" - .009" (.15 - .23)
7011, 7018	.010" - .014" (.10 - .36)	.005" - .007" (.13 - .18)	.017" - .020" (.43 - .51)	.012" - .016" (.30 - .41)	.004" - .007" (.10 - .18)	.006" - .009" (.15 - .23)

MAXIMUM OPERATING LIMITS				
MODEL	RPM	PRESSURE PSI (mbar)	VACUUM in. Hg (mbar)	TEMPERATURE RISE F° (C°)
2002	5275	12 (825)	16 (540)	225 (125)
2004	5275	7 (480)	16 (540)	185 (103)
3002	3600	15 (1035)	16 (540)	210 (116)
3003	3600	12 (825)	15 (508)	180 (100)
3006	3600	7 (480)	15 (508)	170 (94)
4002	3600	15 (1035)	16 (540)	220 (122)
4005	3600	10 (690)	16 (540)	210 (116)
4007	3600	7 (480)	15 (508)	170 (94)
5003	2850	15 (1035)	16 (540)	195 (108)
5006	2850	13 (900)	16 (540)	195 (108)
5009	2850	7 (480)	15 (508)	160 (89)
6005	2350	15 (1035)	16 (540)	250 (139)
6008	2350	14 (965)	16 (540)	240 (133)
6015	2350	7 (485)	12 (410)	180 (100)
7006	2050	15 (1035)	16 (540)	235 (130)
7011	2050	10 (690)	16 (540)	210 (116)
7018	2050	6 (415)	12 (410)	120 (66)

COMPETITOR^{PLUS}™

MAINTENANCE AND SERVICE SPECIFICATIONS SHEET RECOMMENDED LUBRICANTS AND CAPACITIES

RECOMMENDED MINERAL BASED LUBRICANTS

AMBIENT TEMPERATURE	SHELL	CITGO	CHEVRON TEXACO	EXXONMOBIL
0° F (-18° C) to 32° F (0° C)	TELLUS® PLUS 68 (ISO 68)	A/W 68 (ISO 68)	RANDO HD 68 (ISO 68)	DTE HEAVY MEDIUM (ISO 68)
32° F (0° C) to 90° F (32° C)	TELLUS® PLUS 100 (ISO 100)	A/W 100 (ISO 100)	RANDO HD 100 (ISO 100)	DTE HEAVY (ISO 100)
90° F (32° C) to 120° F (50° C)	TELLUS® PLUS 150 (ISO 150)	A/W 150 (ISO 150)	RANDO HD 150 (ISO 150)	DTE EXTRA HEAVY (ISO 150)

RECOMMENDED SYNTHETIC BASED LUBRICANTS FOR ROTARY BLOWERS *

AMBIENT TEMPERATURE	TUTHILL	EXXONMOBIL	SHELL	<p>NOTE: Tuthill Vacuum & Blower Systems cannot accept responsibility for damage to seals, O-rings and gaskets caused by use of synthetic lubricants not recommended by Tuthill Vacuum & Blower Systems.</p> <p>* Blowers used in oxygen-enriched service should use only Castrol Brayco 1726 Plus non-flammable, PFPE synthetic lubricant.</p> <p>Blowers used in hydrogen service should use only PneuLube synthetic oil.</p>
0° F (-18° C) to 32° F (0° C)	PneuLube™ (ISO 100)	SHC 626 (ISO 68)	MADRELA® AS 68 (ISO 68)	
32° F (0° C) to 90° F (32° C)		SHC 627 (ISO 100)	MADRELA® P 100 (ISO 100)	
90° F (32° C) to 120° F (50° C)		SHC 629 (ISO 150)	MADRELA® P 150 (ISO 150)	

RECOMMENDED MINERAL BASED, FOOD GRADE LUBRICANTS FOR ROTARY BLOWERS

AMBIENT TEMPERATURE	Lubricant meeting U.S. FDA regulations 21 CFR 172.878 and 178.3620(a) for direct and indirect food contact	Lubricant meeting U. S. FDA regulation 21 CFR 178.3570 governing petroleum products which may have incidental contact with food (formerly USDA H1 requirements)
0° F (-18° C) to 32° F (0° C)	CITGO CLARION® 350 FOOD GRADE (ISO 68)	CITGO CLARION® A/W 68 (ISO 68)
32° F (0° C) to 90° F (32° C)	CONSULT FACTORY	CITGO CLARION® A/W 100 (ISO 100)
90° F (32° C) to 120° F (50° C)	CONSULT FACTORY	CONSULT FACTORY

OIL RESERVOIR CAPACITIES *

MODEL	FLUID OUNCES (mL)	
	HORIZONTAL FLOW	VERTICAL FLOW
2002, 2004	1.7 (50)	3.4 (100)
3002, 3003, 3006	3.0 (90)	5.1 (150)
4002, 4005, 4007	5.1 (150)	6.8 (200)
5003, 5006, 5009	6.8 (200)	16.9 (500)
6005, 6008, 6015	16.9 (500)	25.4 (750)
7006, 7011, 7018	20.3 (600)	28.7 (850)

* Oil capacities are based on filling from dry condition. Less oil may be needed depending on emptiness of oil reservoir (gear housing) after draining.

Always fill the gear housing until oil drips out of the oil level hole. Replace plugs in their respective holes. Following this procedure will insure proper oil level.

RECOMMENDED GREASE FOR DRIVE END:

Use NLGI #2 premium grade, petroleum base grease with high temperature resistance and good mechanical stability, such as PneuLube grease available from your local Tuthill Pneumatics Sales Professional. Using a pressure gun, force new grease into each bearing until traces of clean grease come out of the relief fitting.

FOR FOOD GRADE APPLICATIONS:

CITGO CLARION® Food Grade HTEP NLGI #2 premium grade grease with high temperature resistance and good mechanical stability that is USDA authorized for use as an H1 lubricant in meat and poultry plants under the federal inspection program. It meets FDA Regulation 21 CFR 178.3570 for lubricants having incidental contact with food.

SPECIAL TOOL DRAWINGS

All dimensions shown are in inches.

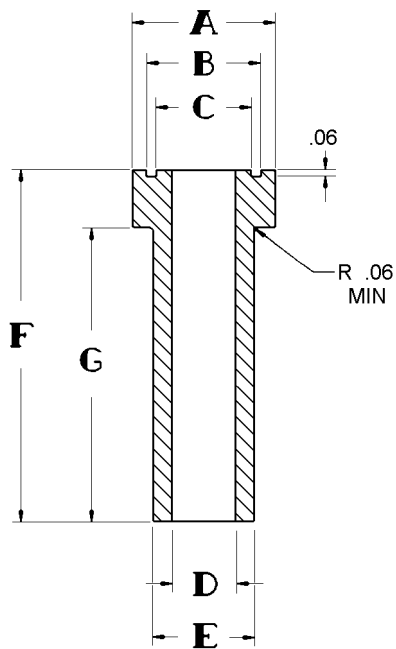

MODEL	PART NUMBER	A	B	C	D	E	F	G
2000	2200718B	1.560 ±.001	1.27 ±.005	.98 ±.005	.70 ±.005	1.10 ±.005	3.50 ±.005	3.00 ±.005
3000	3300718B	2.035 ±.001	1.70 ±.005	1.335 ±.005	1.015 ±.005	1.415 ±.005	3.75 ±.005	3.00 ±.005
4000	4200718B	2.425 ±.001	2.02 ±.005	1.61 ±.005	1.21 ±.005	1.61 ±.005	4.50 ±.005	3.75 ±.005
5000	5300718B	2.820 ±.001	2.42 ±.005	1.81 ±.005	1.41 ±.005	1.81 ±.005	5.00 ±.005	4.25 ±.005
6000	6500718B	3.135 ±.001	2.73 ±.005	2.00 ±.005	1.605 ±.005	2.00 ±.005	6.25 ±.005	5.50 ±.005
7000	7600718B	3.525 ±.001	2.98 ±.005	2.46 ±.005	1.605 ±.005	2.00 ±.005	6.25 ±.005	5.50 ±.005

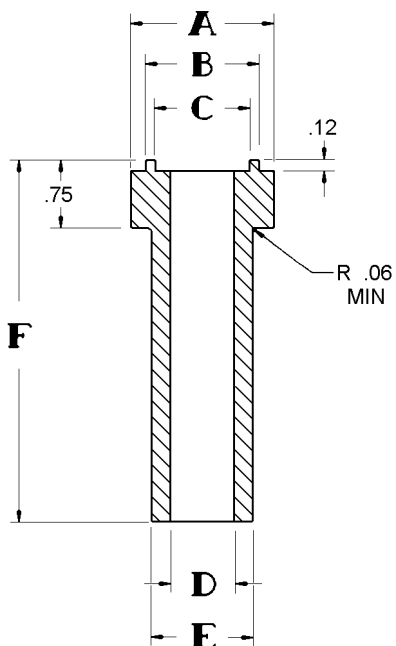

MODEL	PART NUMBER	A	B	C	D	E	F
2000	2200708B	1.560 ±.001	1.24 ±.005	1.04 ±.005	.70 ±.005	1.10 ±.005	4.00 ±.005
3000	3300708B	2.035 ±.001	1.74 ±.005	1.54 ±.005	1.015 ±.005	1.415 ±.005	4.37 ±.005
4000	4200708B	2.425 ±.001	1.865 ±.005	1.665 ±.005	1.21 ±.005	1.61 ±.005	5.25 ±.005
5000	5300708B	2.820 ±.001	2.427 ±.005	2.227 ±.005	1.41 ±.005	1.81 ±.005	5.68 ±.005
6000	6500708B	3.135 ±.001	2.74 ±.005	2.54 ±.005	1.605 ±.005	2.00 ±.005	7.00 ±.005
7000	7600708B	3.525 ±.001	2.99 ±.005	2.79 ±.005	1.605 ±.005	2.00 ±.005	7.00 ±.005

COMPETITOR^{PLUS}™

CUTAWAY VIEW AND PARTS LIST

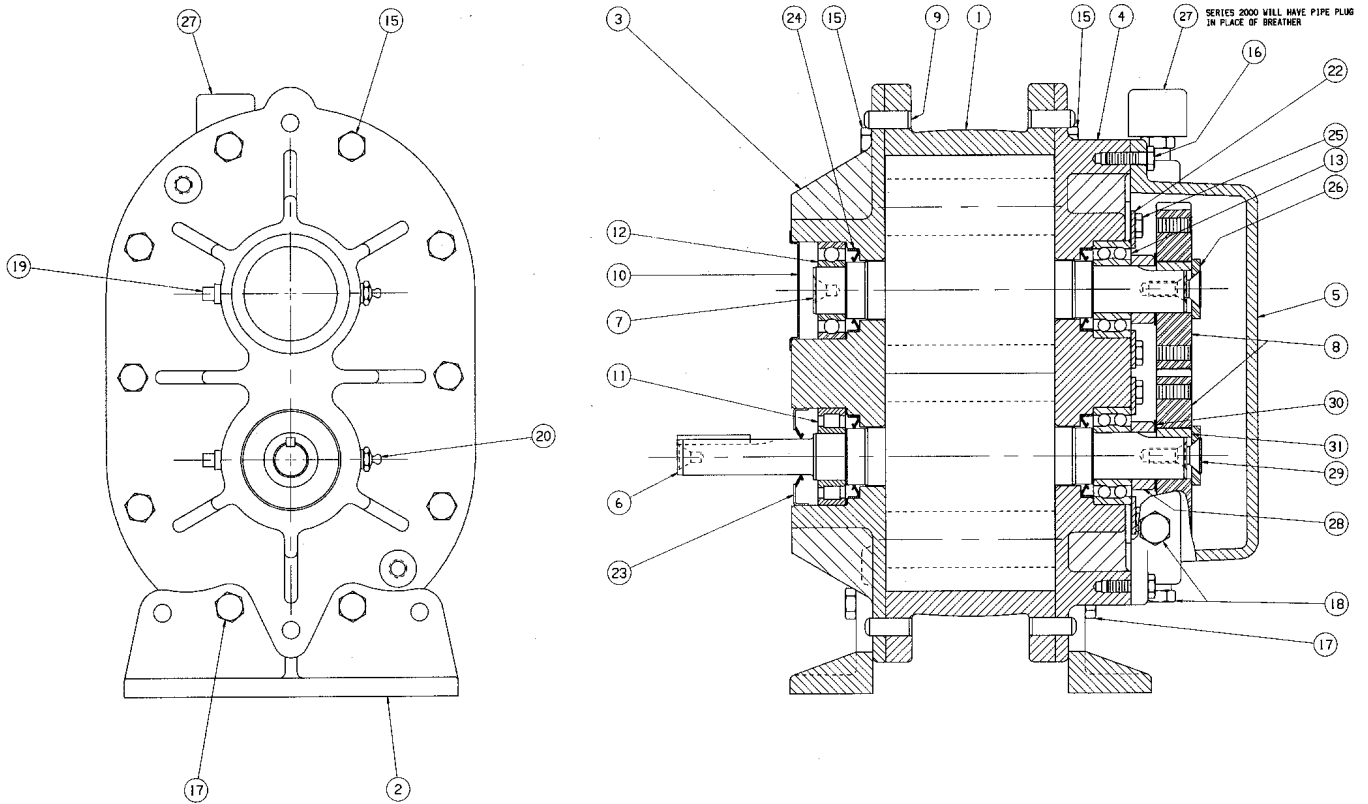

ITEM	DESCRIPTION	QTY	ITEM	DESCRIPTION	QTY
1	Housing	1	18	Plug, Oil	3
2	Mounting Foot	2 *	19	Relief Fitting	2
3	Drive End Plate	1	20	Grease Fitting	2
4	Gear End Plate	1	22	Bearing Retainer	4
5	Gear Cover	1	23	Lip Seal, Drive Shaft	1
6	Drive Rotor	1	24	Lip Seal	4
7	Driven Rotor	1	25	Screw, Hex Head	4
8	Timing Gear	2	26	Washer	2
9	Dowel Pin	4	27	Breather	1 †
10	Bearing Cover Plate	1	28	Spacer	2
11	Roller Bearing, Drive Shaft	1	29	Screw, Hex Head	2
12	Bearing	1	30	Timing Shims	10
13	Bearing	2	31	Gear Timing Key	2
15	Screw, Hex Head	16	42	Alum. Nameplate Kit	1
16	Screw, Hex Head	8 **	43	Dr, Screw	2
17	Screw, Hex Head	4	47	Teflon Vent Insert	8

* Item 2: Models 6005, 6008, 6015, 7006, 7011 and 7018 require (2) each of left and right feet.

** Item 16: Models 5003, 5006 and 5009 require (6) each.

† Item 27: Models 2002 and 2004 requires a pipe plug in lieu of breather.

When ordering parts, use the item number shown, plus your model and serial number.

WARRANTY

Subject to the terms and conditions hereinafter set forth and set forth in General Terms of Sale, Tuthill Vacuum and Blower Systems (the seller) warrants products and parts of its manufacture, when shipped, and its work (including installation and start-up) when performed, will be of good quality and will be free from defects in material and workmanship. This warranty applies only to Seller's equipment, under use and service in accordance with seller's written instructions, recommendations and ratings for installation, operating, maintenance and service of products, for a period as stated in the table below. Because of varying conditions of installation and operation, all guarantees of performance are subject to plus or minus 5% variation. (Non-standard materials are subject to a plus or minus 10% variation)

Product Type	Type of Application	
	Atmospheric Air or Process Air Without Liquids Present	Process Gases Other Than Air, or Any Liquid Injected Application
New	24 months from date of shipment, or 18 months after initial startup date, whichever occurs first	18 months from date of shipment, or 12 months after initial startup date, whichever occurs first
Repair	12 months from date of shipment, or remaining warranty period, whichever is greater	12 months from date of shipment, or remaining warranty period, whichever is greater

THIS WARRANTY EXTENDS ONLY TO BUYER AND/OR ORIGINAL END USER, AND IN NO EVENT SHALL THE SELLER BE LIABLE FOR PROPERTY DAMAGE SUSTAINED BY A PERSON DESIGNATED BY THE LAW OF ANY JURISDICTION AS A THIRD PARTY BENEFICIARY OF THIS WARRANTY OR ANY OTHER WARRANTY HELD TO SURVIVE SELLER'S DISCLAIMER.

All accessories furnished by Seller but manufactured by others bear only that manufacturer's standard warranty.

All claims for defective products, parts, or work under this warranty must be made in writing immediately upon discovery and, in any event within one (1) year from date of shipment of the applicable item and all claims for defective work must be made in writing immediately upon discovery and in any event within one (1) year from date of completion thereof by Seller. Unless done with prior written consent of Seller, any repairs, alterations or disassembly of Seller's equipment shall void warranty. Installation and transportation costs are not included and defective items must be held for Seller's inspection and returned to Seller's Ex-works point upon request.

THERE ARE NO WARRANTIES, EXPRESSED, IMPLIED OR STATUTORY WHICH EXTEND BEYOND THE DESCRIPTION ON THE FACE HEREOF, INCLUDING WITHOUT LIMITATION, THE IMPLIED WARRANTIES OF MERCHANTABILITY AND FITNESS OF PURPOSE.

After Buyer's submission of a claim as provided above and its approval, Seller shall at its option either repair or replace its product, part, or work at the original Ex-works point of shipment, or refund an equitable portion of the purchase price.

The products and parts sold hereunder are not warranted for operation with erosive or corrosive material or those which may lead to build up of material within the product supplied, nor those which are incompatible with the materials of construction. The Buyer shall have no claim whatsoever and no product or part shall be deemed to be defective by reason of failure to resist erosive or corrosive action nor for problems resulting from build-up of material within the unit nor for problems due to incompatibility with the materials of construction.

Any improper use, operation beyond capacity, substitution of parts not approved by Seller, or any alteration or repair by others in such manner as in Seller's judgment affects the product materially and adversely shall void this warranty.

No employee or representative of Seller other than an Officer of the Company is authorized to change this warranty in any way or grant any other warranty. Any such change by an Officer of the Company must be in writing.

The foregoing is Seller's only obligation and Buyer's only remedy for breach of warranty, and except for gross negligence, willful misconduct and remedies permitted under the General Terms of Sale in the sections on **CONTRACT PERFORMANCE, INSPECTION AND ACCEPTANCE** and the **PATENTS** Clause hereof, the foregoing is **BUYER'S ONLY REMEDY HEREUNDER BY WAY OF BREACH OF CONTRACT, TORT OR OTHERWISE, WITHOUT REGARD TO WHETHER ANY DEFECT WAS DISCOVERED OR LATENT AT THE TIME OF DELIVERY OF THE PRODUCT OR WORK.** In no event shall Buyer be entitled to incidental or consequential damages. Any action for breach of this agreement must commence within one (1) year after the cause of action has occurred.

July, 2002



**NO POSTAGE
NECESSARY
IF MAILED
IN THE
UNITED STATES**

BUSINESS REPLY MAIL
FIRST-CLASS MAIL PERMIT NO. 2912 SPRINGFIELD MO

POSTAGE WILL BE PAID BY ADDRESSEE

ATTN CUSTOMER SERVICE
TUTHILL VACUUM AND BLOWER SYSTEMS
PO BOX 2877
SPRINGFIELD MO 65890-2150

